

INTRODUCTION TO THE 2009 ACTIVE SOIL GAS ADVISORY

**Vapor Intrusion Workshops
June 2009**

**Elizabeth Allen
California Environmental Protection Agency
San Francisco Bay Regional Water Quality Control Board**



HOW? WHAT? WHEN?

- **History and makeup**
- **How we got here today**
- **Summary of proposed changes**
- **Next steps**



LOOKING BACK

- **1997 LARWQCB *Advisory for Active Soil Gas Investigations***
- **2003 DTSC/LARWQCB Update**
- **2007 Working Group formed to update 1997/2003 documents**



SOIL GAS ADVISORY WORKGROUP

- **14 core members**
- **Representatives from DTSC, LARWQCB, SFRWQCB**
- **Began work in summer 2007**



THE ROAD TO TODAY

- **Internal working draft, November 2007**
- **Solicitation of input from stakeholders in January 2008**
- **Public forums held in March 2008 in Sacramento and Los Angeles**



WHAT TO EXPECT

- **Combined Cal/EPA document**
- **Emphasis on CSM and DQOs**
- **Vertical contaminant profiling**
- **Encourage using temporary/permanent vapor probes**
- **Discourage using post-run tubing**



WHAT TO EXPECT

- **Waiting period after rain**
- **Longer equilibration times for intrusive drilling methods**
- **Provides for use of gas leak check compounds**
- **Longer hold time for Summa[®] canisters**
- **Tubing type recommendations**

WHAT TO EXPECT

- **Use of TO-17 for naphthalene**
- **ELAP certification for analytical methods**

NEXT STEPS

- **Peer-review draft June 2009**
- **Legal review**
- **Public comment Fall 2009**



2003 Advisory – Active Soil Gas Investigation Upcoming Revisions

Theodore Johnson
Geological Services Unit
Department of Toxic Substances Control
tjohnson@dtsc.ca.gov
June 2009



Revisions to the 2003 Advisory

- Revised document supersedes 2003 Advisory
- Combines 2003 Advisory and LARWQCB 1997 *Interim Guidance for Active Soil Gas Investigation* into one comprehensive document
- **This talk presents only proposed changes to 2003 Advisory**



Revisions to the 2003 Advisory

- Provides investigation flexibility using Data Quality Objectives (DQOs) instead of prescriptive language.
 - Sample spacing
 - Sample depths
 - Detection limits
 - Analytical methods



Revisions to the 2003 Advisory

- Expanded workplan section
 - Addition of Site Conceptual Model (CSM)
 - Purpose of CSM
 - Basic components in a CSM
 - Elements of the Workplan
- Report section
 - Assess and revise CSM
 - Identify data gaps based on revised CSM



Revisions to the 2003 Advisory

- Initial sampling at 2 depths based on DQOs and CSM
 - 5 feet (ft) below ground surface (bgs)
 - 10 to 15 ft bgs
- Link to Vapor Intrusion (VI) investigations
 - Vapor sample depths for VI investigations
- Revises the vertical profiling section
 - Based on DQOs



Revisions to the 2003 Advisory

- Sampling tubing
 - Appropriate tubing for chemicals sampled
 - No longer recommends copper or low density polyethylene tubing
 - Appendix lists chemicals and appropriate tubing composition for vapor sampling and probe design.



Revisions to the 2003 Advisory

- Probe construction
 - Post-run tubing method is discouraged/ not recommended
- Equilibration times (i.e., sampling delay following probe installation)
 - Hollow stem auger or hand auger – 48 hours
 - Rotosonic or air rotary methods – 2 weeks



Post-Run Tubing

Modified from McAlary 2006

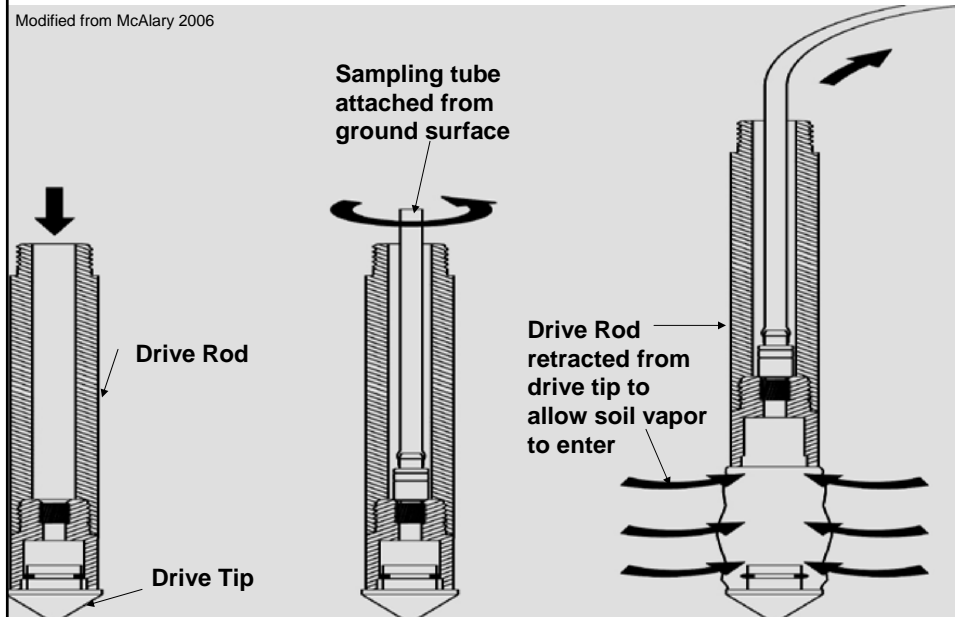

Revisions to the 2003 Advisory

- Sub-slab sampling
 - Sampled at a slower rate (50 mL/min) than vadose zone sampling
 - Maintain low vacuum
 - References DTSC Vapor Intrusion Guidance, Appendix G for sub-slab probe installation



Revisions to the 2003 Advisory

- Purge Volumes
 - Increases final purge volume to 10 times
 - Purge volume calculation included with “Soil Gas Probe Typical Construction” figure
 - Reduces resampling frequency from 20 to 10% when:
 - A new purge volume is used based on widely varying lithology or
 - a new constituent of concern is detected



Revisions to the 2003 Advisory

- Leak Check
 - Shut-in test for sampling system
 - From soil gas probe to sampling container
 - New list of compounds
 - Liquid tracer compounds, such as hexane, pentane, n-propanol
 - Gaseous tracer compounds, such as helium, isobutene, propane, and butane, can be used along with appropriate shrouding or tenting



Revisions to the 2003 Advisory

- Leak Check (cont.)
 - Qualitative vs. Quantitative
 - Qualitative analysis
 - Quantified at detection limit (DL) of target analytes.
 - If the concentration of leak check compound is 10X the DL for target analyte(s), then it will indicate corrective action is necessary.



Revisions to the 2003 Advisory

- Leak Check (cont.)
 - Quantitative
 - Use of gaseous tracer with shrouding or tenting to determine percent of ambient air leak into a collection vessel.
 - Leaks in excess of 10% of sample should be mitigated.
 - Procedures for quantitative leak test are described in Appendix B and will be discussed by Bryan Eya.



Revisions to the 2003 Advisory

- Purge and Sampling Rates
 - Purge rates between 100 to 200 mL/min **and vacuums <100 inches of water for standard small diameter (1/8 to 1/4 inch) tubing should be maintained.**



Revisions to the 2003 Advisory

- Purge and Sampling Rates (cont.)
 - Depth-dependent sampling rates
 - For soil gas sampling from larger diameter tubing (such as those for deep vapor wells extending beyond 40 ft bgs), higher flow rates (>200 mL/min) can be used if vacuum of ≤ 100 inches of water is maintained during sampling.



Revisions to the 2003 Advisory

- Purge and Sampling Rates (cont.)
 - Depth-dependent sampling rates
 - For samples <5 feet deep, extensive purging or use of large volume sample containers (e.g., 6L-SUMMA™) should be avoided due to potential ambient-air introduction.
 - To reduce ambient air intrusion, maintain a slower flow rate (≤ 50 mL/min) and a low vacuum of <10 inches of water.



Revisions to the 2003 Advisory

- Sample Containers
 - Use of plastic syringes are discouraged. Glass syringes are preferred
 - Samples collected using Tedlar™ bags or glass bulbs with surrogates added within 15 minutes of collection should be analyzed within 6 hours after collection (see Appendix E).



Revisions to the 2003 Advisory

- Sample Containers
 - Use of alternate sample containers:
 - *Samples should be collected in gas-tight containers and handled in a manner that will prevent photodegradation of the target analytes.*



Revisions to the 2003 Advisory

- Sample Collection
 - **Soil Gas Sampling in Low-Permeability Soil**
 - Soil gas sampling from low permeability material is produced with:
 - (1) good annular seals;
 - (2) careful monitoring of flow and vacuum during purging and sample collecting; and
 - (3) using tracer gas for leak-testing.
 - Further detail on sampling in low-permeability soil will be discussed by Bryan Eya.



Revisions to the 2003 Advisory

- Sample Collection
 - **Tedlar™ Bags**
 - A vacuum chamber or lung sampler should be employed when using Tedlar™ bags.
 - Allows filling Tedlar™ bag without passing vapor through pump.
 - The pump draws a vacuum within chamber or container and resulting pressure differential causes sample to be drawn through sampling tube into Tedlar™ bag.



Vacuum Chamber or Lung Sampler

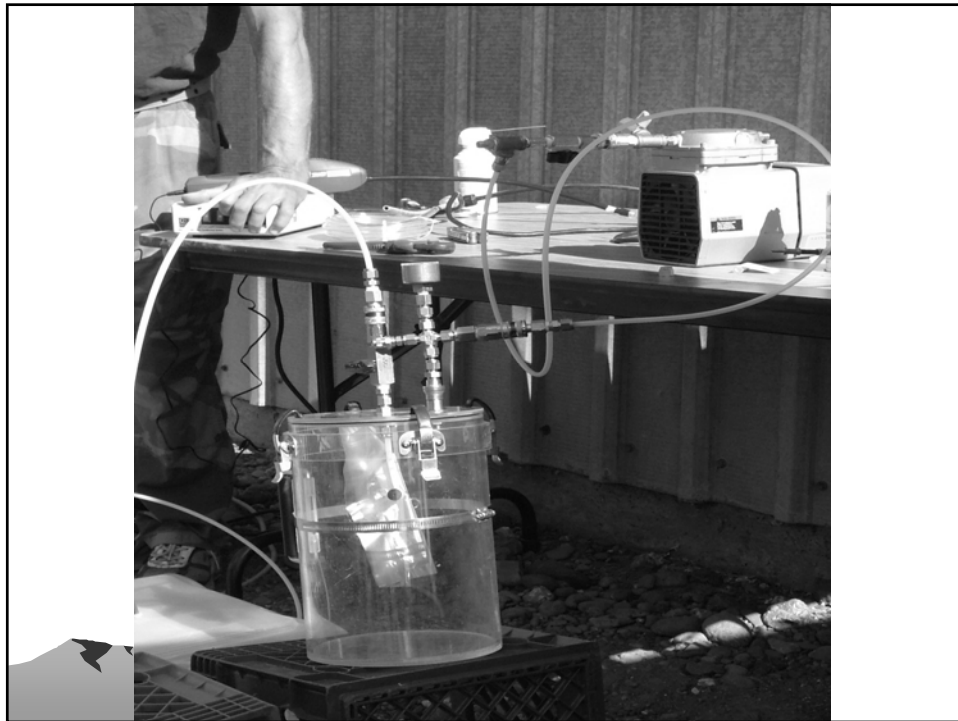
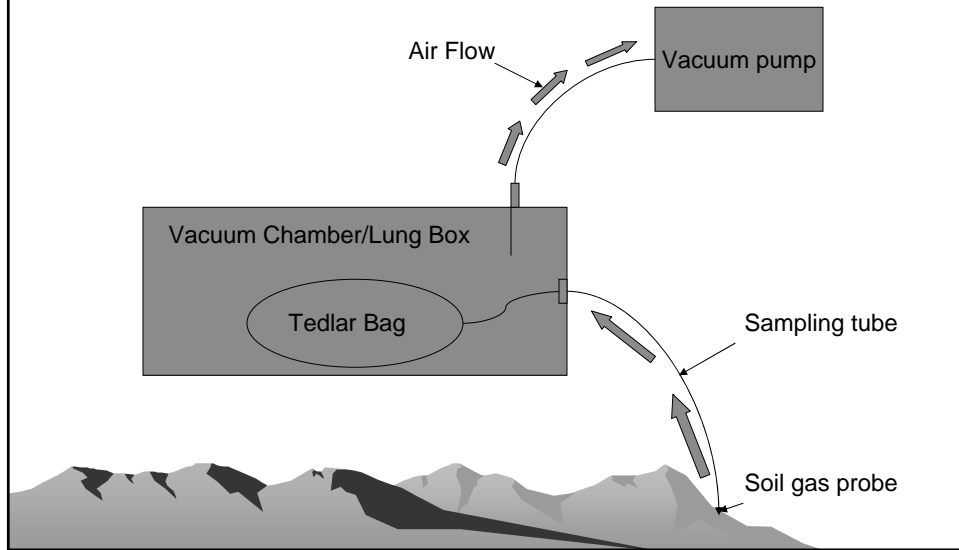

Revisions to the 2003 Advisory

- Sample Collection
 - Soil gas sample collection using sorbents for Method TO-17
 - Soil gas sampling for analysis by Method TO-17 is described in Appendices C and F.
 - TO-17 may be used for other volatile constituents depending on project DQOs.
 - Further detail on TO-17 will be discussed by Peter Wong.



Revisions to the 2003 Advisory

- Field conditions
 - Rainfall (Appendix D)
 - Soil gas sampling should not be conducted:
 - during or **within 5 days of a significant rain event** (1/2 inch or greater);
 - or
 - where the following conditions occur:
 - Irrigation or watering of soil,
 - Standing or ponded water areas.



Revisions to the 2003 Advisory

- Field conditions (cont.)
 - **Barometric Pressure** (Appendix D)
 - Soil gas sampling should be delayed until frontal systems have passed the area.
 - Alternatively, soil gas sampling times and depths may be chosen to minimize the effects of changes in barometric pressure.
 - Corrective measures for low flow conditions



Revisions to the 2003 Advisory

- Analytical Methods
 - Combined 1997 LARWQCB lab sections with 2003 Advisory
 - Target compounds
 - Text and appendices discuss EPA methods
 - 8260B/C, TO13A, TO15, and TO17
 - Laboratory certification
 - In depth discussion by Peter Wong



Revisions to the 2003 Advisory

- Holding Times
 - Soil gas samples collected in glass bulbs or Tedlar™ bags with surrogates added within 15 minutes of collection may be analyzed within **6 hours after collection.**
 - Soil gas samples collected in Summa™ canisters may be analyzed **within 14 days from collection.**



Revisions to the 2003 Advisory

- Detection Limits
 - Project-specific DLs should be based on DQOs.
 - DLs should be quantitative and \leq reporting limit.
 - Tracer compound should be adjusted to be in same concentration range as analytes.



Revisions to the 2003 Advisory

- Appendices
 - Passive Soil Gas Method
 - Quantitative Leak Check Procedure
 - Naphthalene Collection Method
 - Soil Gas Analytical Method Review



VAPOR INTRUSION WORKSHOP UPDATE ON LABORATORY METHODS AND CERTIFICATION

Peter Wong
Research Scientist II
Environmental Chemistry Laboratory
Department of Toxic Substances Control
June 2009

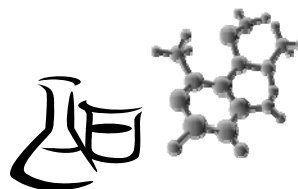

ANALYTICAL METHODS UPDATE

- Current Methods
 - “modified” EPA 8015
 - “modified” EPA 8021
 - “modified” EPA 8260
 - “modified” EPA TO-13A
 - “modified” EPA TO-15



NEW METHOD

- “Modified” EPA METHOD TO-17
- *“Determination of Volatile Organic Compounds in Ambient Air Using Sampling Onto Sorbent Tubes”*

3

“MODIFIED” EPA METHOD TO-17

- Soil gas collected in sorbent tubes/cartridges
- Thermally desorbed into gas chromatograph (GC)
- Collection method

4

“MODIFIED” EPA METHOD TO-17

- Gas Chromatography/Mass Spectrometry (GC/MS) analysis – follows EPA Method TO-15
- Vapor (gas) phase standard or liquid standards
- Recommended for naphthalene
- Quality Control (QC) on sorbent tubes/cartridges

5

QUALITY CONTROL UPDATE

- Concerns about “*matrix-matching*” when using liquid standards
- Validation of liquid standard calibration curves with vapor (gas) phase standards
- Validate all new calibration curves;
% difference \leq 20%



6

QUALITY CONTROL UPDATE

- Routinely validate with each analytical batch; % difference $\leq 20\%$
- Compounds where % difference is $>20\%$ can be reported with disclaimer
- No validation needed if vapor (gas) standards are used to prepare calibration curve

7

APPENDIX F

- “Primer” on soil gas testing
- Review of methods
 - Instrumentation
 - Modifications for soil gas testing
 - “Advantages” and “Disadvantages”



8

APPENDIX F

- Lab Quality Assurance/Quality Control (QA/QC) basics and recommendations
- Detection limits/reporting limits
- Reporting units
- Comparing results
- Laboratory certification

9

LABORATORY CERTIFICATION

- Soil gas testing methods will be certified by the Environmental Laboratory Accreditation Program (ELAP)
- ELAP certification is coming!
- Initiate with issuance of new soil gas advisory



10

LABORATORY CERTIFICATION

Certification will be available for soil gas testing with “modified” EPA methods

- EPA 8015
- EPA 8021
- EPA 8260
- EPA TO-13A
- EPA TO-15
- EPA TO-17

11

LABORATORY CERTIFICATION

- Field of Testing 116
- *“Volatile Organic Chemistry of Hazardous Waste”*
 - EPA 8015
 - EPA 8021
 - EPA 8260
 - EPA TO-15
 - EPA TO-17
- Field of Testing 117
- *“Semi-volatile Organic Chemistry of Hazardous Waste”*
 - EPA TO-13A



12

LABORATORY CERTIFICATION

National Environmental Laboratory Accreditation Program (NELAP) Accreditation for

- TO-13A
- TO-15
- TO-17



Will be accepted in lieu of ELAP certification for these methods in soil gas

13

LABORATORY CERTIFICATION

- Amendment process for currently-certified labs
- Application process for new labs
- **DO NOT CONTACT ELAP YET!**
- Details need to be worked out



14

LABORATORY CERTIFICATION

- New Laboratory Certification Process
 - Application
 - Fees
 - Inspection
 - Performance Evaluation (PE)/Blind Samples



- Amendment Process
 - Application
 - Fees
 - Inspection/Document Review
 - PE/Blind Samples



15

LABORATORY CERTIFICATION

- Labs currently certified for 8015, 8021 and 8260 for soil and water matrices need to apply for an amendment to their certification for soil gas.
- Soil gas will be listed as a separate matrix for those methods.

16

LABORATORY CERTIFICATION

- Certification for TO methods is for soil gas only, **not** air.
- For air testing with TO methods, need NELAP accreditation.

17

LABORATORY CERTIFICATION

- For soil gas TO methods, labs must have the designated instrumentation/setup for those methods.
 - Passivated canisters
 - Water management system

18

DTSC's *Vapor Intrusion Guidance*

Bill Bosan, PhD
Human & Ecological Risk Division
Department of Toxic Substances Control
bbosan@dtsc.ca.gov
June 2009



DTSC Vapor Intrusion Guidance

- *Overview:* Dr. Bill Bosan
- *Vapor Intrusion Risk Assessment
CHHSLs:* Dr. Kimi Klein
- *Sampling Considerations:* Dr. Bryan Eya
- *Upcoming Changes to the Vapor
Intrusion Guidance:* Mr. Dan Gallagher



11 Steps in DTSC Vapor Intrusion Guidance Process

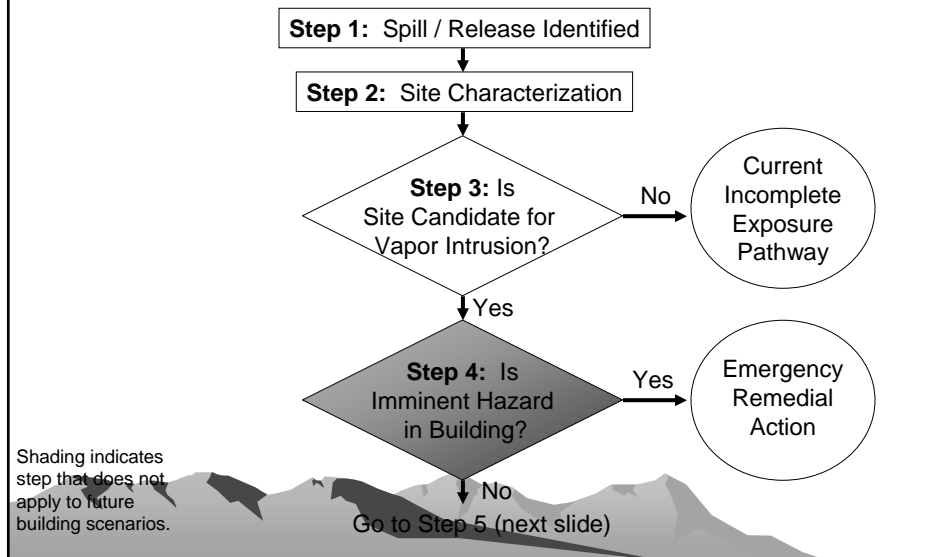

11 Steps in DTSC Vapor Intrusion Guidance Process

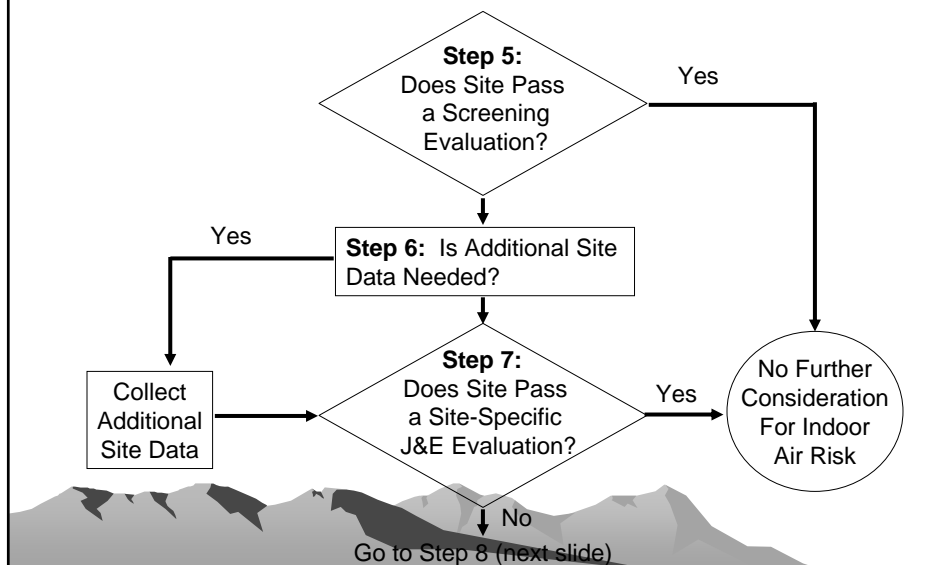

11 Steps in DTSC Vapor Intrusion Guidance Process

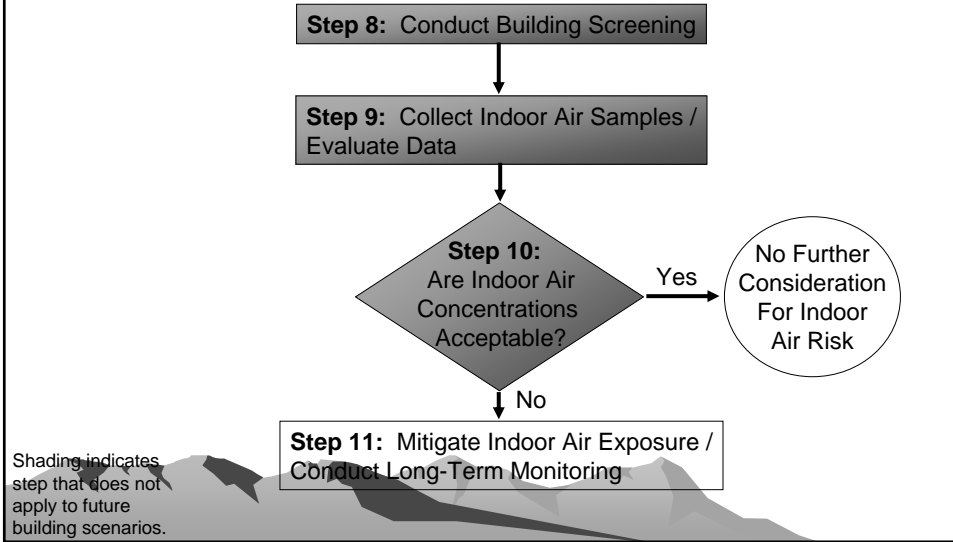

Vapor Intrusion Risk Assessment California Human Health Screening Levels (CHHSLs)

Kimi Klein, Ph.D.
Human and Ecological Risk Division
California Department of Toxic Substances Control (DTSC)
kklein@dtsc.ca.gov
916 255 6643
510 540 3762
June 2009

Environmental Concerns in Site Cleanup

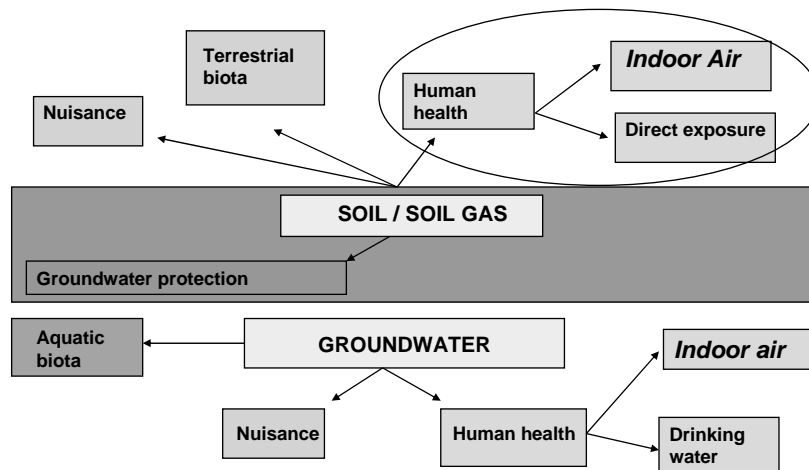

Legislative Background

- ◆ SB32 – California Land Environmental Restoration and Reuse Act
- ◆ CHHSLs developed by the Cal/EPA Office of Environmental Health Hazard Assessment (OEHHA)
- ◆ "may be used ... to estimate the degree of effort that may be necessary to remediate a contaminated property".

What are CHHSLs?

- ◆ Soil or soil vapor concentrations of 60 chemicals that have been determined to be below thresholds of concern for risks to human health
 - Target thresholds:
 - ◆ One-in-a-million risk for carcinogens
 - ◆ hazard quotient of one for non-carcinogens
- ◆ Non-regulatory and advisory in nature – use of CHHSLs is voluntary

CHHSLs, RSLs and ESLs

- ◆ CHHSLs – California Human Health Screening Levels (OEHHA)
 - Uses California toxicity criteria to calculate safe soil or soil gas levels
 - Considers indoor air exposure pathway for volatile organic compounds (VOCs)
- ◆ ESLs – Environmental Screening Levels (SFRWQCB)
- ◆ RSLs - Regional Screening Levels (USEPA)
 - Replaces PRGs – Preliminary Remediation Goals
 - Does not evaluate the indoor air pathway

06/2009

5

How were CHHSLs developed?

- ◆ Models and exposure assumptions used
 - US EPA “Superfund” methodology
 - ◆ Similar to the DTSC Preliminary Endangerment Assessment (PEA) Guidance Manual
 - Vapor intrusion model to address the inhalation of contaminated indoor air for VOCs

06/2009

6

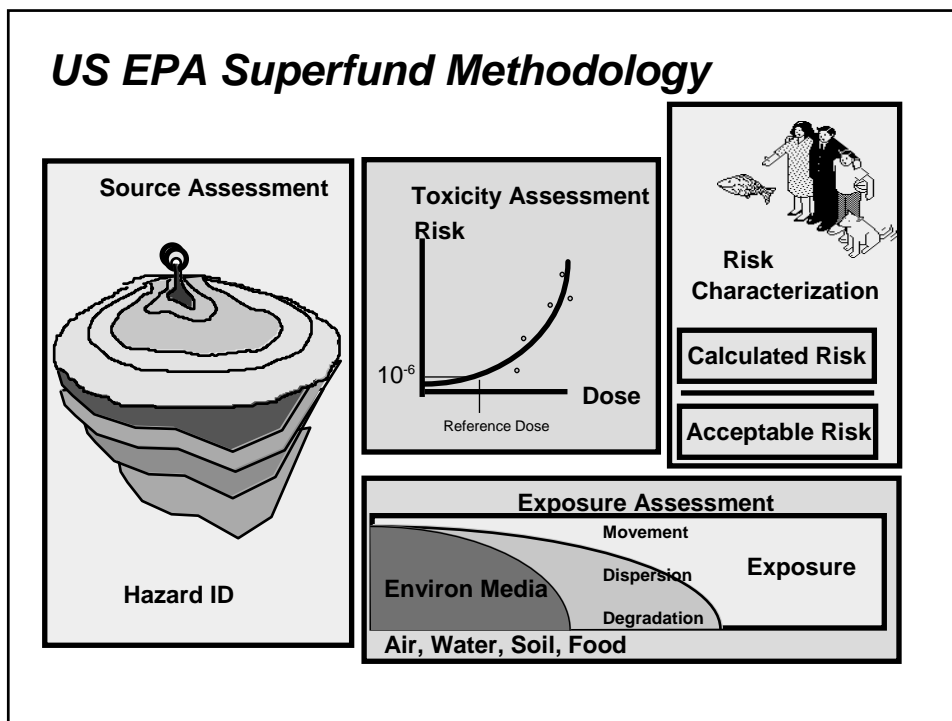

Exposure Pathways used in CHHSL Calculation

- ◆ For non-volatile chemicals (soil-bound):
 - Incidental soil ingestion
 - Dermal absorption
 - Inhalation of dusts in outdoor air

- ◆ For **VOCs**:

- Inhalation of indoor air contaminated by vapors intruding from the sub-surface
- Direct exposure is not included for VOCs

Basic CHHSL Equations

- ◆ Chemical-specific dose is calculated by rearranging these equations:
 - Target Risk = Chronic Daily Dose x Cancer Slope Factor (CSF)
 - Target Non-Cancer Hazard = $\frac{\text{Daily Dose}}{\text{Reference Dose}}$
- ◆ Dose = soil or air concentration x residential or industrial default exposure factors
- ◆ Soil or air level is calculated by rearranging the dose equation

06/2009

9

Calculating a CHHSL for a VOC

- ◆ Dose equation for inhalation solves for a chemical-specific air concentration
- ◆ How to get from an air concentration to a soil gas concentration?
 - The vapor intrusion model looks at the way soil gas moves through soil to indoor air and calculates an attenuation factor (alpha)

06/2009

10

Estimating a Soil Gas CHHSL from a Target Indoor Air Concentration

- Alpha = $\frac{\text{Indoor Air Concentration}}{\text{Soil Gas Concentration}}$
- The vapor intrusion model calculates the alpha assuming:
 - ◆ Sandy soils
 - ◆ One-story slab-on-grade building
 - ◆ Specific chemical properties
- Solve for target soil gas concentration = volatile chemical CHHSL

06/2009

11

Vapor Intrusion – Conceptual Model

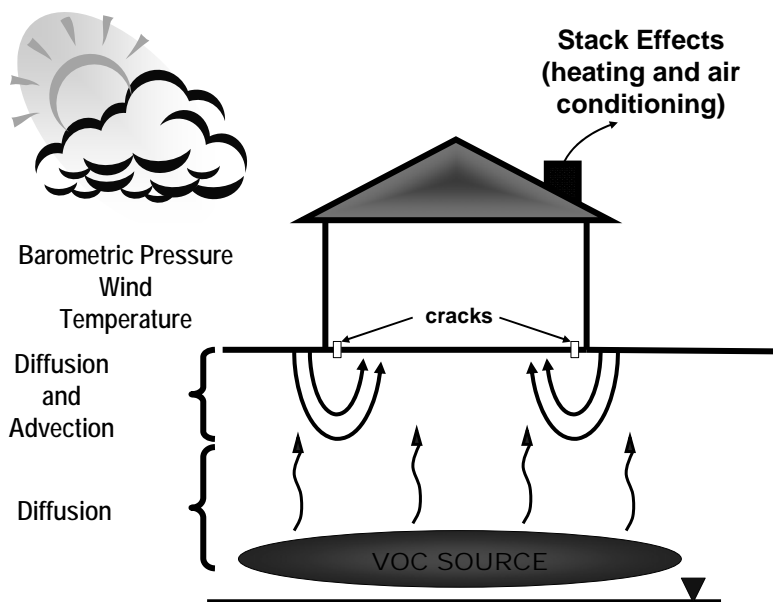

CHHSLs for VOCs

- ◆ Four lists in Table 2 - CHHSLs Users Manual
- ◆ Residential CHHSLs - without engineered fill (existing building)
 - Target Indoor Air Levels
 - Target Soil Gas Levels
- ◆ Commercial/Industrial CHHSLs – without engineered fill (existing building)
 - Target Indoor Air Levels
 - Target Soil Gas Levels

06/2009

13

Other Target Soil Gas Levels

- ◆ Table 6 of Appendix 1 - CHHSLs Users Manual
- ◆ Residential and Commercial/Industrial Levels with engineered fill (future building)
- ◆ The assumption of engineered fill increases the distance between potential source and indoor air space
 - Therefore, slightly less conservative

06/2009

14

How may a CHHSL be used?

- ◆ As a screening value
- ◆ As a cleanup value – if agreed upon by all parties
- ◆ At **simple** sites/facilities

06/2009

15

What is a Simple Site?

- ◆ No potential for ecological impacts
- ◆ No potential for transport of contaminants to ecological habitats
- ◆ Soil contamination only with no potential to affect groundwater or surface water
- ◆ All potential exposure pathways match the pathways used to calculate CHHSLs

06/2009

16

Environmental Concerns in Site Cleanup

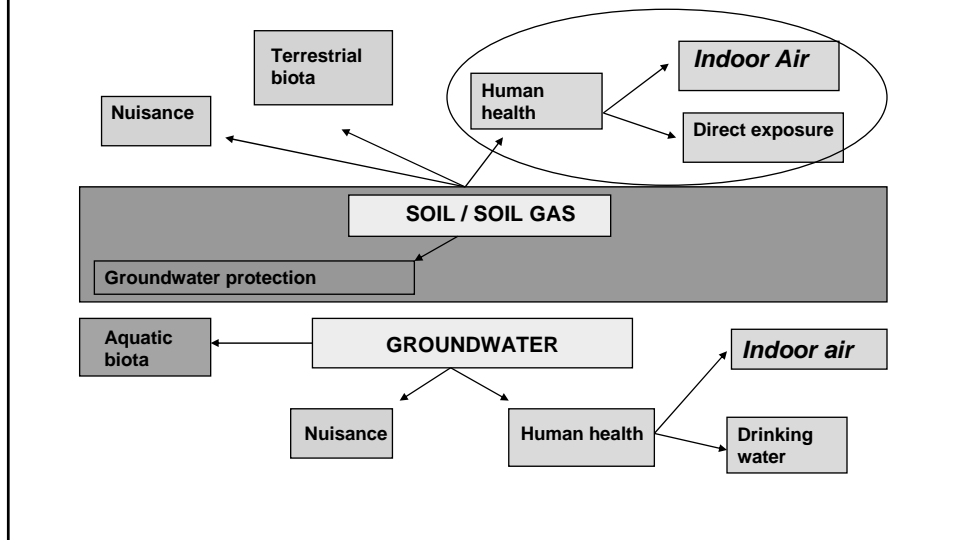

When should CHHSLs **NOT** be used?

- ◆ Not as walk-away values
 - Ecological and leaching concerns must also be evaluated
- ◆ Not if food pathways may be complete
- ◆ Not to screen out chemicals before calculating cumulative risk from the site

What about VOCs that do not have CHHSLs?

- ◆ Consult a Risk Assessor/Toxicologist to:
 - use method described in Appendix 1 of CHHSLs Guidance for volatile chemicals
 - or:
 - ◆ Use US EPA air RSLs as target residential or industrial air concentrations
 - ◆ Divide air RSL by a default alpha to get rough estimate of target soil gas concentration

06/2009

19

Calculate Cumulative Risk and Hazard Index (HI) for All Chemicals

$$\text{◆ Risk} = \left[\frac{(\text{conc}_x)}{\text{CHHSL}_x} + \frac{(\text{conc}_y)}{\text{CHHSL}_y} \right] \times 10^{-6}$$

$$\text{◆ HI} = \left[\frac{(\text{conc}_x)}{\text{CHHSL}_x} + \frac{(\text{conc}_y)}{\text{CHHSL}_y} \right]$$

06/2009

20

What is an Acceptable Risk?

◆ Carcinogens

- Background cancer cases:
 - ◆ 1 in 3
- Site-specific area:
 - ◆ 1 in 10,000 to 1 in 1,000,000
- Therefore, excess risk:
 - ◆ 0.3301 to 0.330001

What is an Acceptable Hazard?

◆ Non-carcinogens

- Add Hazard Quotients for all chemicals
- Acceptable total HI: less than 1

◆ When the HI is more than 1:

- Look at toxicity assessment for each chemical
 - ◆ What is the sensitive organ affected?
- Add HIs by target organ
- Acceptable organ-specific HI: less than 1

CHHSL Issue – VOCs

- ◆ Since direct exposure to VOCs is not included in the calculation of CHHSLs, what do we do about volatile chemicals tightly bound to solid matrices?
- ◆ Example: naphthalene
- ◆ Soil vapor data are necessary at sites with volatile chemicals to assess risk
- ◆ Use RSLs to confirm completion of soil removal for VOCs?

06/2009

23

Naphthalene as a carcinogen

- ◆ OEHHA has declared naphthalene a carcinogen by the inhalation route.
 - Unit Risk Factor: $3.4 \times 10^{-5} (\mu\text{g}/\text{m}^3)^{-1}$
- ◆ Compare this toxicity criterion to that for benzene:
 - Unit Risk Factor: $2.9 \times 10^{-5} (\mu\text{g}/\text{m}^3)^{-1}$
- ◆ Therefore, naphthalene at your site could drive the risk assessment.

06/2009

24

Other VOCs

- ◆ Ethyl Benzene as a carcinogen
- ◆ Evaluation of Total Petroleum Hydrocarbons

06/2009

25

New/Revised Draft CHHSLs

| <u>Chemical</u> | <u>Residential</u> | <u>Industrial/ Commercial</u> |
|-----------------|--|---|
| Beryllium | 16 mg/kg | 190 mg/kg |
| Lead | 80 mg/kg | 320 mg/kg |
| Ethyl Benzene | 490 $\mu\text{g}/\text{m}^3$ (Soil gas) | 1600 $\mu\text{g}/\text{m}^3$ (Soil gas) |

06/2009

26

New Sampling Considerations for DTSC Vapor Intrusion Process

Bryan K. Eya, Ph.D.
Human & Ecological Risk Division
Department of Toxic Substances Control

Update
Soil Gas Sampling Method to
Address Vapor Intrusion

SUMMARY

- New sampling consideration added to the Advisory include:
 - Sampling in low-permeability soil
 - Passive soil gas sampling
 - Sampling considerations for naphthalene

Statement of the Problem

- Why is revision required?
 - Advisory was not written for addressing VI
 - Originally developed for delineating soil gas impacts to evaluate threat to GW, landfill gas migration, identifying UST leaks, monitor SVE progress
 - In recent years, soil gas sampling is increasingly used for assessing VI
- Limitation of current version:
 - Ignores tight formation (defers to soil matrix)
 - Assumes no VI for site with low-perm soil

Sampling from Low-Permeability Soil

- Common misconception - vapor transport is negligible if gas permeability is low
- Vapor transport in unsaturated soil is dominated by diffusion, *not by permeability*
- Effective diffusion (D_{eff}):
 - **Ratio of D_{eff} : Sand/Clay = 10 (approx.)**
- Intrinsic Permeability (k_i):
 - **Ratio of k_i : Sand/Clay = 10,000 (approx.)**

Challenges with Low-Perm Soil

- Many guidance recommend collecting soil gas at a fixed flow rate regardless of permeability
- If permeability is not sufficient to satisfy flow:
 - Abandon locations where sample cannot be obtained
 - Very strong vacuum up to 30 inches of Hg or 408 inches of H₂O is applied (initial vacuum of SUMMA)
 - upsets phase partitioning or draw H₂O
- Potential for more probe leak for low-perm soil
 - Shallow sampling depth (high water table)

How Do You Address Low-Perm Condition?

- Soil gas sampling should be based on both flow rate and vacuum
- Vacuum is a function of flow, so low-flow conditions should be defined using both flow and vacuum
- Based on API 2005 - applied vacuum can be limited to 100-inches of water column to minimize phase partitioning or drawing water
- Flow and vacuum should be measured by permeability testing (*important test*)

How is Permeability Measured and What is Low-Flow Probe?

- Flow and vacuum measurements are made at about 3 flow rates (e.g., 100, 200 and 500 mL/min)
- Ratio of flow rate (Q) and applied vacuum (s) is Q/s (known as specific capacity), which is linearly proportional to gas permeability
- Steady flow and vacuum are typically achieved within ≤ 15 sec at each flow rate
- Probes where the minimum flow rate (100 mL/min) cannot be sustained at max vacuum of 100-inches of H₂O are referred to as low-flow probes.

Soil-Gas Permeability Testing

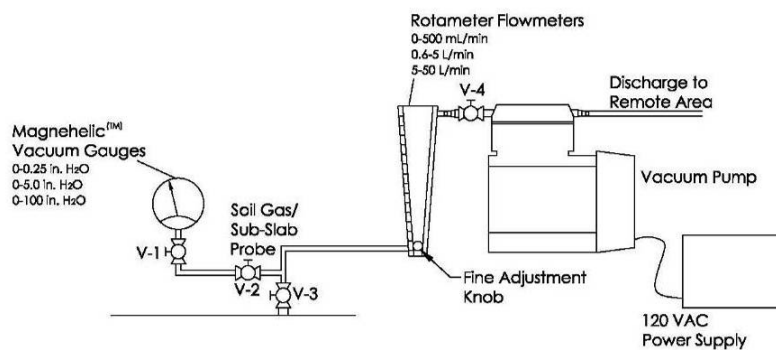

An example of soil-gas permeability testing equipment (McAlary et al., 2009)

Yield from low flow probe

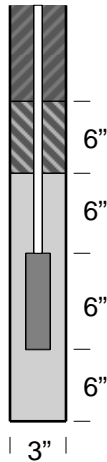

How much soil gas can be extracted from a low-flow probe each time (the Yield) during each purge under applied vacuum of 100-inches of H₂O can be calculated using Ideal Gas Law (Boyle's Law): $P_1V_1 = P_2V_2$

As an example based on probe construction: 18" sand pack & 6" bentonite in 3" ID borehole w/ 6-foot (3/16" ID) tubing & 6" screen (0.25" ID)

About 300 mL of Soil Gas can be extracted (ca. 400 mL including transfer line)

Other Challenges with Low-Perm - Ambient Air Leak in Sample

➤ To avoid leaks use:

- Use semi-permanent probes with hydrated bentonite throughout the annulus with compression fittings
- Avoid temporary probes (direct push probes with post-run tubing)
- Do Shut-In Test
- Do tracer leak testing with helium

Shut-in Test (after API, 2005)



- Connect all the fittings
- Evacuate line and “shut-in” vacuum
- Monitor vacuum for a few minutes
- Adjust fittings if needed to hold vacuum

Geosyntec, 2007

Helium Leak Testing

- Advantages of He tracer test:
 - Can be performed in Field & in Lab
 - Reasonably quantitative
 - Useful where some leak may be unavoidable in Low-Perm Soil, especially at shallow depths
- Small leaks are acceptable $\leq 5\%$
- Do not have to move the probe location

Helium Leak Test Cont.

- Field screen for leak can be performed using Tedlar bag in a lung-box and a helium meter
- Laboratory analysis of helium also possible using modified EPA Method TO-3
- Unlike qualitative leak test using alcohols and 1,1-DFE
 - Small contribution from leak test compound does not result in analytical dilution to raise RL

Example Apparatus for Field Screening and Sampling using Helium Tracer

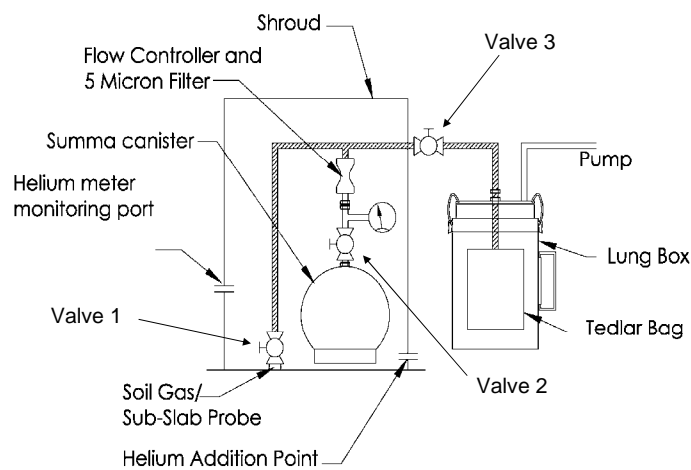

An example of sampling and leak testing equipment (McAlary et al., 2009)

Helium Tracer Data



Add about 10% He to shroud, and confirm with field screening

Monitor He in Tedlar bag prior to sample collection

Also possible to have laboratory measure He in canister

15

Geosyntec, 2007

Low-Flow Probe Sampling

- Modified purge & sampling procedure
 - ca. 300 mL withdrawn with vacuum of 100-in of H₂O
 - Close probe to dissipate vacuum (several minutes to typically overnight)
- Process repeated until desired purge volume (e.g., 1L) and sample volume (e.g., 0.6L) or residual vacuum in Summa < 10 in Hg

Passive Soil Gas Method

- Effective in detecting VOCs in soil gas from areas with low permeability and high moisture settings
- Works by diffusion
 - No forced movement of soil gas
- Other guidance documents recommend passive method for low-perm soil site characterization
- Qualitative method
 - Consists of burial of adsorbent material into subsurface

Passive Soil Gas Method (Cont.)

- Measures mass (e.g. μg) of VOCs adsorbed
- Exposure time is ca 10-14 days
- Passive sampler types:
 - Membrane-based polymeric & carbonaceous resin (GORE-SORBER®)
 - Hydrophobic adsorbent cartridge encased in a glass vial (EMFLUX®)
 - Activated carbon adsorption elements (PETREX®)

Passive Soil Gas Method (Cont.)

- Other Advantages:
 - Provides additional line of evidence
 - Lateral delineation of soil gas plume
 - Locate contaminant hotspots & determining plume limits
 - Locate preferential pathways
 - Detecting VOC at very low concentrations
 - Cost effective
 - Simplicity in installation and retrieval
 - Sometimes paired with sorbent/TO-17

Naphthalene Soil Gas Sampling & Analyses

- Need representative sample for VI
- Several active methods can be used:
 - Modified Compendium Method TO-17 (Active Sampling onto Sorbent Tubes, Tenax)
 - Modified Compendium Method TO-15 (SUMMA Canister)
 - Modified SW846 USEPA Method 5030B/8260B (Purge-&-Trap for Aqueous Sample/VOC by GC/MS)
- Passive method

Comparison of Conventional TO-15 & TO-17 Methods

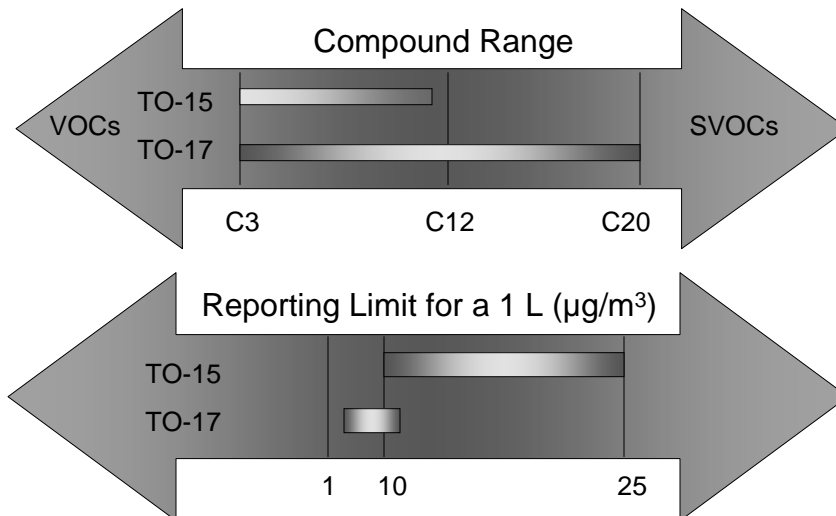

* 5030/8260: Naph purges well; RL = 20 $\mu\text{g}/\text{m}^3$ Adapted from AirToxics 2008

TO-15 & TO-17 Disadvantages

- TO-15
 - Naphthalene has lower volatility (0.087 mm Hg) than the vapor pressure limit of TO-15 (0.1 mm Hg) - may condense on internal hardware surfaces of concentrator to give erratic result
- TO-17
 - Unfamiliarity of this technique
 - Concerns with perceived limitations of sorbents
 - Column breakthrough; MS overload; "one-shot deal"

Example of How to Collect Naphthalene using TO-17

- Use semi-permanent probes with hydrated bentonite throughout the annulus with compression fittings
- Use vacuum < 100-inches H₂O
- Tracer testing (He for shallow probes)
- Low flow rate \leq 100 mL/min (e.g., 50 mL/min for 30 min)

Example of How to Collect Naphthalene using TO-17 (Cont.)

- Two 3.5"-Tenax GR traps in series with 200 mg Tenax per tube to monitor breakthrough
- Field duplicates with trip blank
- See following example from AirToxics (April 2008)

Two Tenax GR in Series



AirToxics, 2008

Instruments to Overcome Disadvantages

- For TO-17
 - Updated Thermal Desorption instrumentation allows reruns as well as dilution (not “one-shot deal” - repeat analysis ; no MS overload)
- For TO-15
 - New innovation in designs to allow recovery of C2 to C25 compounds with extremely low carryover (< 0.1%)
- Recommendation as to which method to use may depend on capability of stationary laboratory
- Performance testing for naphthalene recovery is required if TO-15 (or another method) used

Summary

- Vapor transport is dominated by diffusion & not permeability
- Active soil gas sampling is dependent on Permeability of soil
- Passive sampling based on diffusion may work well for low-perm soil
- Tenax/TO-17 - method of choice for naphthalene

References

- McAlary, T.A., Nicholson, P., Groenevelt, H., Bertrand, D.: "A Case Study of Soil-Gas Sampling in Silt and Clay Rich (Low-Permeability) Soils; Ground Water Monitoring & Remediation, Winter 2009, Vol. 29, no. 1.
- Hayes, H., Mahfood, J., Shamory, B.: "Comparison of EPA Compendium Methods TO-15 and TO-17 for the Measurement of Naphthalene in Soil Gas" in Engineer's Society of Western Pennsylvania Proceeding, April, 2008; <http://www.eswp.com/brownfields/program.htm#TS4>
- ITRC Technical Regulatory Guidance, January 2007, <http://www.itrcweb.org/Documents/VI-1.pdf> & USEPA Brownfields Technology Primer, March 2008, <http://www.brownfieldstsc.org/pdfs>

CHANGES TO DTSC'S VAPOR INTRUSION GUIDANCE

Vapor Intrusion Workshops

**Dan Gallagher
Department of Toxic Substances Control
California Environmental Protection Agency**



June 2009

Major Changes to CA VI Guidance

- **Soil Gas Sampling for Vapor Intrusion**
- **Installation of Permanent Monitoring Probes**
- **Subslab Attenuation Factors**
- **Effective Diffusion Coefficients**
- **Confirmation Sampling**

Constituents of Concern

Table 1 of VIG contains 112 chemicals

- Remove low toxicity, low vapor pressure constituents
- Recommend method for remaining constituents (Method 8260; TO-10, TO-13, TO-15, and TO-17)

Soil Gas Modeling

Theoretical Distribution of Soil Gas Above a Subsurface Contaminant Source

Modified from Johnson and Abreu (AEHS Conference 2005)

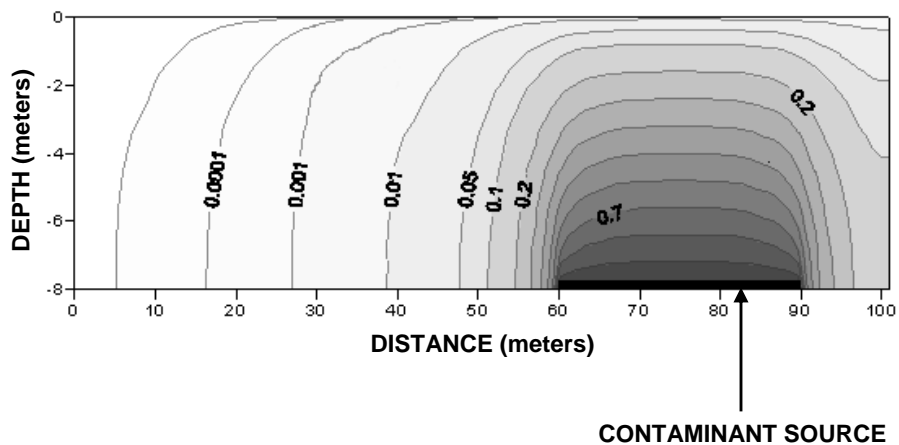

Soil Gas Modeling

Theoretical Distribution of Soil Gas Above a Subsurface Contaminant Source With a Building

Modified from Johnson and Abreu (AEHS Conference 2005)

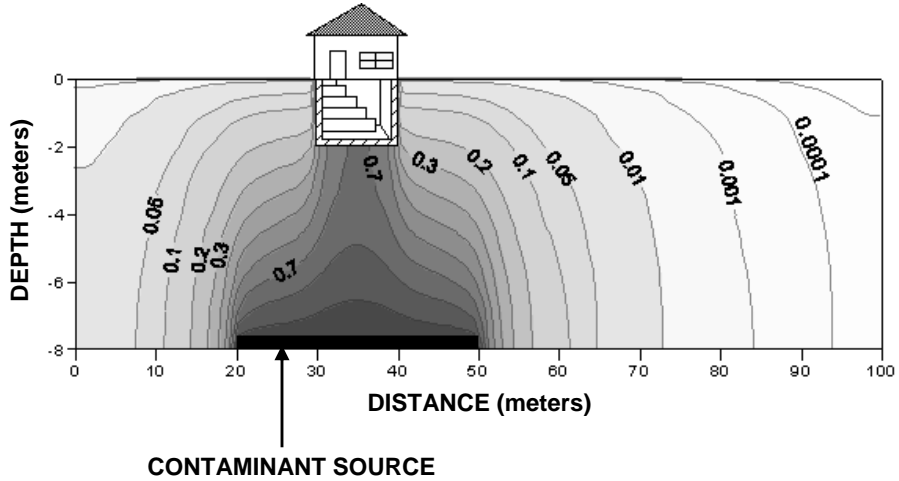

Soil Gas Sampling Depths

Differences in “open-field” and “under-building” soil gas concentrations

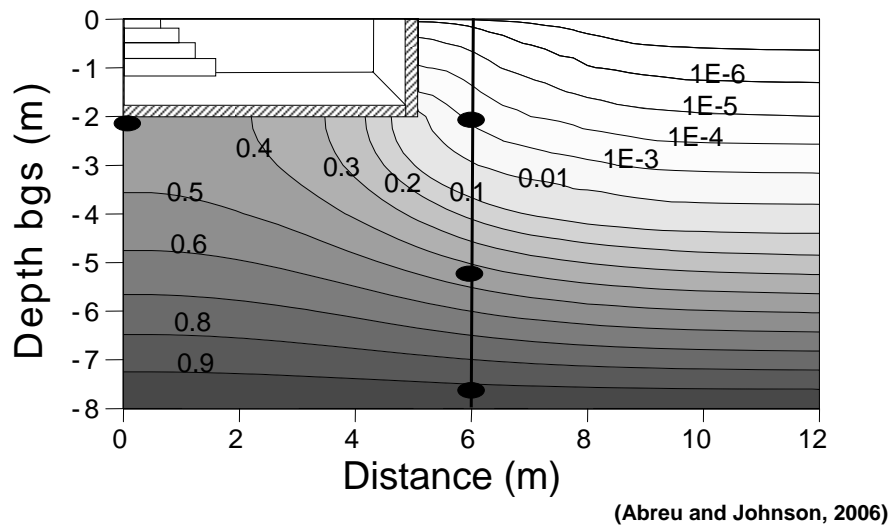

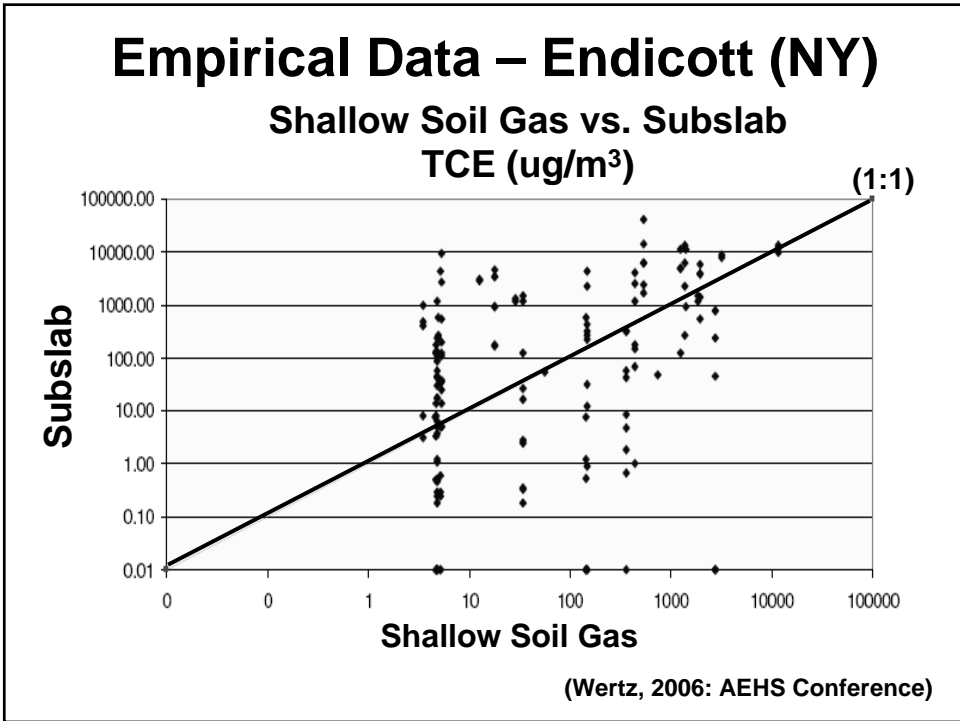
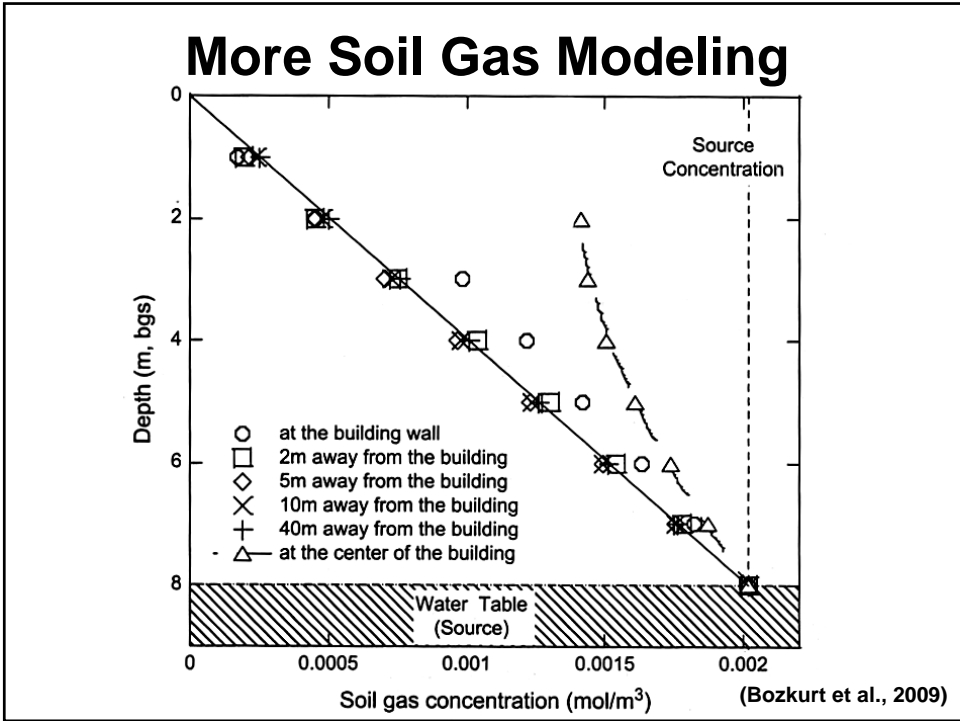

| | |
|--|--|
| | <h2 style="text-align: center;">Soil Gas Sampling Considerations</h2> <h3 style="text-align: center;">Sample Pursuant to a Conceptual Site Model</h3> |
| | <ul style="list-style-type: none"> • Continuous Core for Lithologic Definition • Vertical Soil Gas Sampling to Locate Source • Sample Near Source – Less Sample Variability • Evaluate Risk with Near Source Samples • Multiple Lines of Evidence Should be Considered <p style="text-align: center;">A SINGLE SAMPLING STRATEGY IS NOT APPROPRIATE FOR ALL SITES</p> |

| | |
|--|--|
| | <h2 style="text-align: center;">Installation of Permanent Probes</h2> |
| | <ul style="list-style-type: none"> • Groundwater is less than five feet below grade • Vadose zone is subject to barometric pressure effects (sandy conditions with deep groundwater) • Evaluate whether contamination has reached steady-state |

Installation of Permanent Probes

- **Soil gas grab samples yield an irregular distribution of contamination**
- **Soil gas plumes have migrated under residential buildings**
- **Evaluate the effectiveness of SVE systems**

Attenuation Factors

$$\text{Subslab Attenuation Factor } (\alpha) = \frac{\text{Indoor Air Concentration}}{\text{Subslab Gas Concentration}}$$

DTSC 2005 Guidance: Subslab α = 0.01

Subslab Attenuation

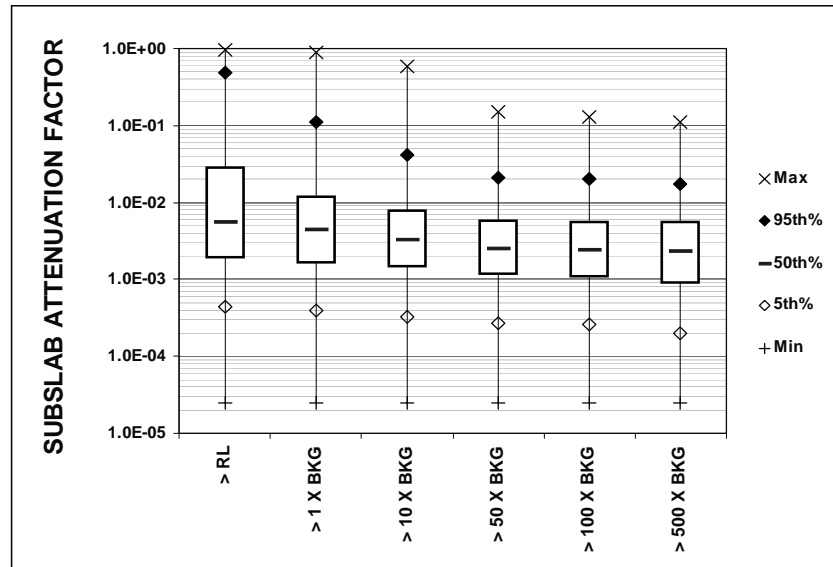

(Taken from Dawson, 2008)

Soil Effective Diffusion Coefficient (D_{eff})

Millington and Quirk (1961)

$$D_{eff} = D_a \left(\frac{\theta^{3.33}}{n^2} \right) + \frac{D_w}{H} \left(\frac{\theta^{3.33}}{n^2} \right)$$

- D_a = diffusion coefficient in air
- D_w = diffusion coefficient in water
- θ = volumetric moisture content
- H = Henry's law constant
- n = total porosity

Sensitivity of Input Parameters

Volumetric Moisture Content of the Soil
(porosity of 43% assumed)

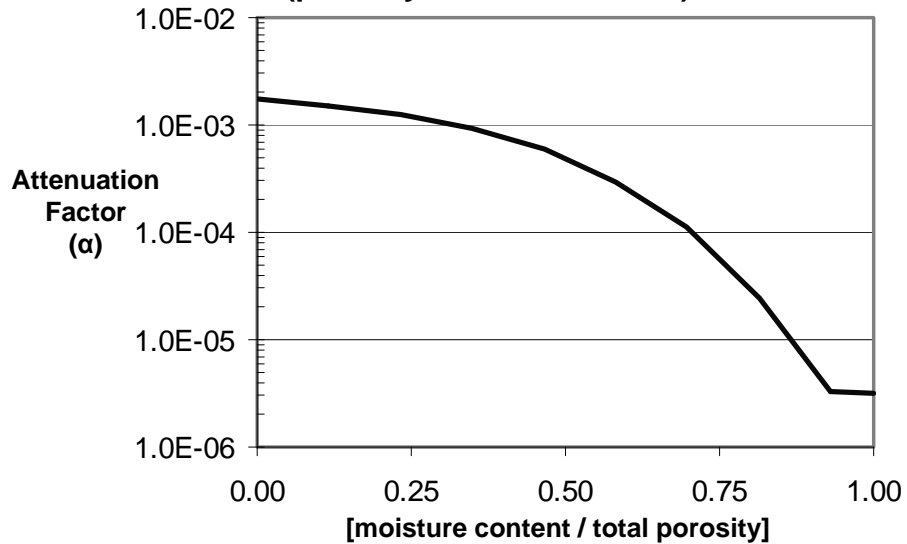

In-Situ Measurement of Effective Diffusion Coefficient

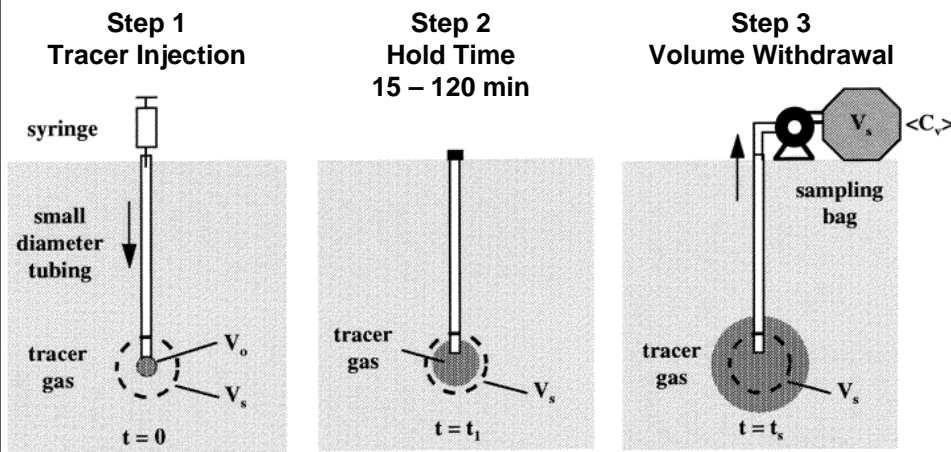

(Johnson et al., 1998)

Post-Remediation Soil Gas Sampling Soil Vapor Extraction Operation

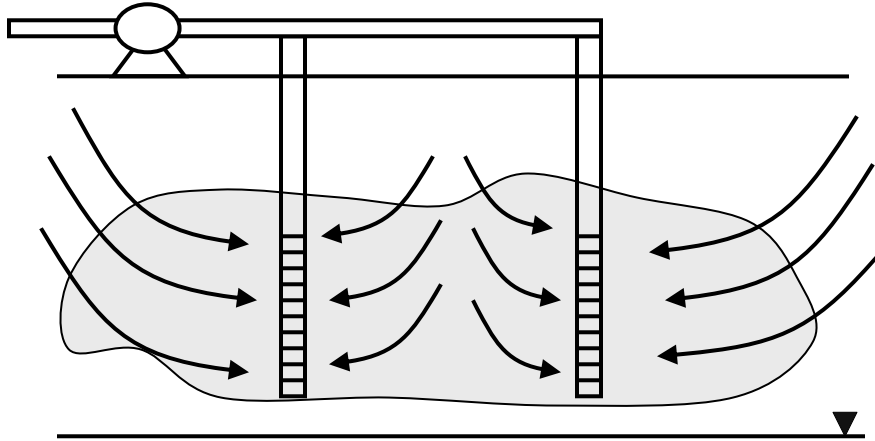

Post-Remediation Soil Gas Sampling Soil Vapor Extraction Completion

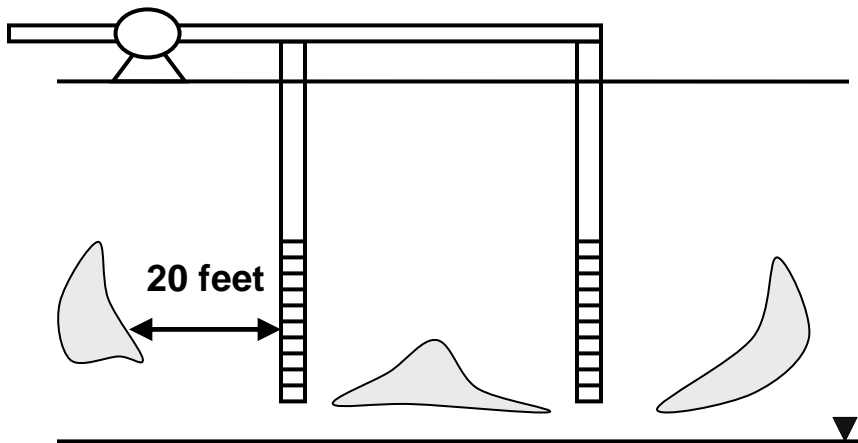

Confirmation Sampling Time to Reach Steady-State Conditions

$$t_{ss} = \frac{R_v \theta_v L^2}{D_{eff}}$$

- t_{ss} = time to near-steady vapor concentration
 R_v = vapor-phase retardation
 θ_v = soil volumetric air content
 L = distance from contaminant source
 D_{eff} = soil effective diffusion coefficient

(Johnson et al., 1999)

Time to Reach Steady-State for PCE

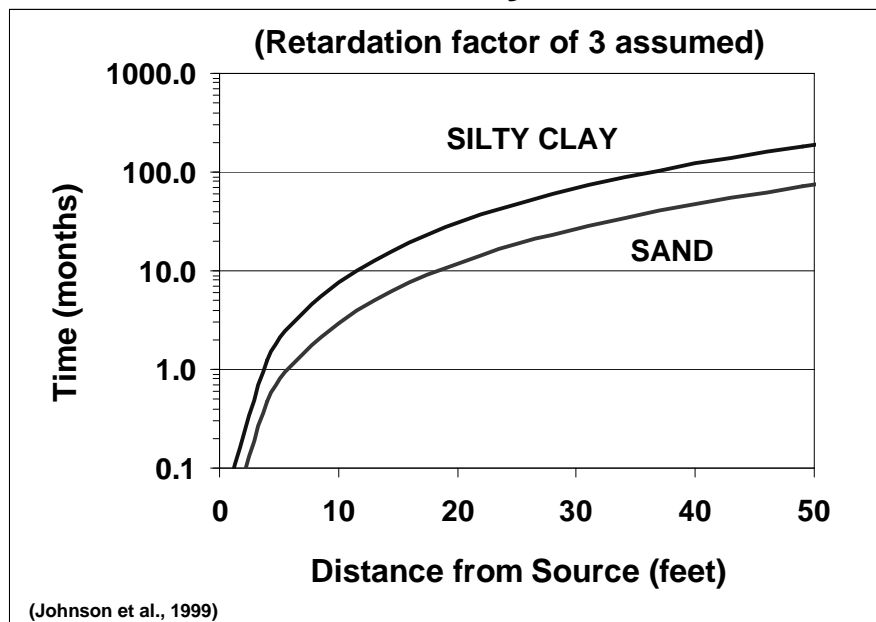

References

1. Borkurt, O., K. Pennell and E. M. Suubery. 2009. Simulation of the Vapor Intrusion Process for Nonhomogeneous Soils Using a Three-Dimensional Numerical Model. *Ground Water Monitoring and Remediation*, v. 29, n. 1, p. 92 – 104.
2. Abreu, L. V., and P. C. Johnson. 2006. Simulating the Effect of Aerobic Biodegradation on Soil Vapor Intrusion into Buildings: Influence of Degradation Rate, Source Concentration, and Depth. *Environmental Science and Technology*, v. 40, p. 2304 – 2315.
3. Dawson, H. 2008. EPA's Vapor Intrusion Database -- Analysis of Attenuation Factors (Groundwater, Subslab, Soil Gas, and Crawlspace) from Multiple Sites. Eighteenth Annual Conference for Association for Environmental Health and Science; San Diego, March 13, 2008. <http://iavi.rti.org/WorkshopsAndConferences.cfm>
4. Johnson, P. C., C. Bruce, R. M. Johnson, and M. W. Kemblowski. 1998. In Situ Measurements of Effective Vapor-Phase Porous Media Diffusion Coefficients. *Environmental Science and Technology*, v. 32, p. 3405 – 3409.
5. Johnson, P.C., M. Kemblowski, and R. L. Johnson. 1999. Assessing the Significance of Subsurface Contaminant Vapor Mitigation to Enclosed Spaces: Site-Specific Alternatives to Generic Estimates. *Journal of Soil Contamination*, v. 8, n. 3, p. 389 - 421.
6. Johnson, P. and L. Abreu. 2005. Vapor Intrusion - Lessons Learned Through Numerical Simulation. Fifteenth Annual Conference for Association for Environmental Health and Science; San Diego, March 14, 2005. <http://iavi.rti.org/WorkshopsAndConferences.cfm>

References

7. Millington, R. J., and M. J. Quirk. 1961. Permeability of Porous Solids. *Trans. Faraday Soc.*, v. 57, p. 1200 – 1207.
8. USEPA. 2008. USEPA's Vapor Intrusion Database: Preliminary Evaluation of Attenuation Factors. Office of Solid Waste, Washington, DC; March 4, 2008. <http://iavi.rti.org/OtherDocuments.cfm?PageID=documentDetails&AttachID=369>
9. Wertz, B. 2006. Near-Building and Subslab Sampling at the Endicott (NY) Site, Implications for Site Screening Approaches. Sixteenth Annual Conference for Association for Environmental Health and Science; San Diego, March 16, 2006. <http://iavi.rti.org/WorkshopsAndConferences.cfm>